

DESIGN AND CONSTRUCTION OF
ELECTRONIC TIME-TABLE DISPLAY
WITH AN OUTPUT VOICE

BY

MAHMUD YUNUSA

DECEMBER, 2011

DESIGN AND CONSTRUCTION OF ELECTRONICS TIME-TABLEB
DISPLAY WITH AN OUTPUT VOICE

BY



MAHMUD YUNUSA

N/EET/09/10092

THIS PROJECT IS SUBMITTED TO THE DEPARTMENT OF
ELECTRICAL/ELECTRONICS ENGINEERING TECHNOLOGY, NUHU
BAMALLI POLYTECHNIC ZARIA, IN PARTIAL FULFILMENT OF THE
REQUIREMENT FOR THE AWARD OF NATIONAL DIPLOMA IN
ELECTRICAL/ELECTRONICS ENGINEERING TECHNOLOGY
DEPARTMENT

DECEMBER, 2011

DECLARATION

I Yunusa Mahmud hereby declare that this project work was undertaken by me under the supervision of Mal. D. Gambo of the Department of Electrical/Electronic Engineering Technology, Nuhu Bamalli Polytechnic, Zaria. Authors whose works were used have been duly acknowledged.



YUNUSA MAHMUD



SIGN/DATE

APPROVAL PAGE

This is to certify that the project is an original work undertaken by Yunusa Mahmud with the Reg. No N/EET/09/10092 and has been prepared in accordance with the regulations governing the preparation and presentation of project in the department of Electrical Electronics Engineering Technology, Nuhu Bamalli Polytechnic, Zaria



MAL. D. GAMBO
(PROJECT SUPERVISOR)

17/04/12

SIGN/DATE

ENGR. MAHMUD A. PANTI
(PROJECT COORDINATOR)

SIGN/DATE

MAL. MUHAMMAD GARBA
(HEAD OF DEPARTMENT)

SIGN/DATE

DEDICATION

I humbly dedicated this project work to my lovely parent in person of Late Alhaji Mahmud Yahaya (may his soul rest in a perfect peace) amen, and that of Hajia Hadiza Mahmud.

ACKNOWLEDGEMENT

With gratitude to Almighty Allah (SAW) who gave me the strength and ability to write this project report. I must also appreciate the effort and support of people who assisted me with vital information upon which make the project a successful one. I must first thank my supervisor Mal. D. Gambo who directed me how to write and arrange this project report.

My special thanks goes to my family of late Ahaji Mahmud Yahaya Aiiyu de and that of late Hajiya Hadiza Mahmud and my brother Saleh Mahmud ay their soul rest in perfect peace).Ameen.

Those who assisted me financially and encouragement toward the completion of this programme. My heartfelt thanks goes to lovely guardians naji Abdullahi Mochammad Aiiyu and wife Hajiya Lubabatu Maje and Justice nta Isah Abbas who stood by me in terms of need. Also, course mates and well shers to all the lecturers in my department

ABSTRACT

The existing conventional ways in which students and even the general public see timetable is the same. As Electrical students, we thought of a possible way to make the difference, that is why the electronic time table display was brought into limelight.

This project comes up with possible means of attracting the attention of the public to be able to see the time table even at night. The timetable is designed and constructed in such a way that the Light Emitting Diode (LEDs) were arranged to display the timetable and the alarm to draw the attention of the students. The design basically utilized rectifiers, pulse generator, NE 555 timer and Decade counter (i.e. CD4017) transistors which act as switches to the Light Emitting Diode (LEDs).

TABLE OF CONTENTS

Title page		
Certification	- - - - -	ii
Declaration	- - - - -	iii
Approval page	- - - - -	iv
Acknowledgement	- - - - -	v
Abstract	- - - - -	vi
CHAPTER ONE		
1.1 Introduction	- - - - -	1
1.2 Motivation	- - - - -	1
1.3 Aims and objectives	- - - - -	2
1.4 Methodology	- - - - -	2
1.5 Scope and limitation	- - - - -	4
1.6 Project organization	- - - - -	4
CHAPTER TWO		
2.0 Literature Review	- - - - -	5
2.1 Historical background-	- - - - -	5
2.2 Components review	- - - - -	6
CHAPTER THREE		
3.0 Design analysis	- - - - -	11
3.1 Design of the power supply	- - - - -	11
3.2 Design of the oscillator	- - - - -	15
3.3 Frequency divider	- - - - -	18

CHAPTER ONE

1.1 INTRODUCTION

The use of a timetable cannot be under estimated. This is technology age and there is no other better way of doing things than improving technology.

Using the electronic time table display instead of the ordinary timetable we all know is as a result of improvement, not just improvement but improvement in technology.

Hundreds of LEDs were used in the construction of this project, for each LED to light visibly well, a current of 15mA will be needed. The power supply must remain the same as the LED flashes.

1.2 MOTIVATION

Majority of people only know about time table but have never heard of the ELECTRONIC TIMETABLE DISPLAY WITH AN OUTPUT VOICE. This electronic timetable display will easily draw the attention of the general public. It was designed in an attractive manner that people will appreciate and it will beat their imaginations. This is first of its kind in the Department of Electrical Electronics Engineering Technology, Nuhu Bamalli Polytechnic Zaria.

1.3 AIMS AND OBJECTIVES

The aim of this project is to design and construct an electronic timetable display with an output voice. The objectives are as follows:

1. To design the electronic timetable display circuit.
2. To construct the circuit
3. To provide a means of understanding the time table
4. Testing the circuit
5. To select materials of this project work

1.4 METHODOLOGY

The method employed in designing and constructing this project is constructing the various unit of the circuit, that is; the power supply unit, pulse generating unit, the counter unit where the outputs are obtained.

The block diagram is shown below: -

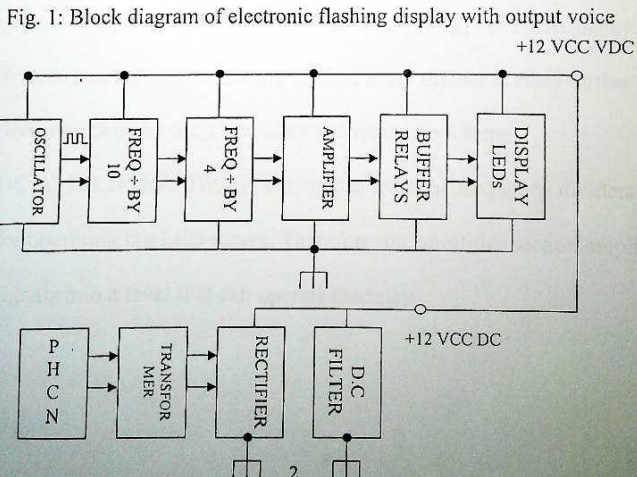

EXPLANATION OF THE BLOCK DIAGRAM

1. **PHCN:** Is the AC input power supply, 220_{vac}
2. **TRANSFORMER:** The AC input is fed into a step-down transformer to slow down the input voltage, to a level suitable for the circuit consumption.
3. **RECTIFIER:** The rectifier converts the input voltage to DC good for the operation of the circuit.
4. **DC FILTER:** Because the rectified AC to DC has some noise and AC components, a capacitive filter is reasonable to smoothen the output to a clean level.
5. **OSCILLATOR:** Is the signal generator responsible for generating some serial turning pulse for determining the turning operation of this project.
6. **FREQUENCY DIVIDER:** Are responsible for stepping down serial pulses generated by the oscillator in to steps or divisions, the 1st frequency divider divides into 10 steps while the 2nd frequency divider divides further the divisions done by the 1st frequency divider into 4 steps.
7. **DC AMPLIFIER:** The divider signals from the frequency dividers are used for operating the LED arrays. Therefore, the amplifier section amplifies the signals into a level that can operate the relay.

8. **BUFFERS:** In reality the relays were used as the buffer to separate or isolate the LEDs from the control circuit but amplifying control signals from the control.

1.5 SCOPE AND LIMITATION

This project is concerned with the design and construction of several gadgets. It finds application in where the mode of operation is not to be known by everybody. Hence,

- A very heavy rain can stop the circuit from working if the water enters it.
- Care should be taken to ensure that each turned pulse is positioned neatly before any soldering take place.
- Components and materials used should be considerable factors for the project such factors as manufacturing factors, service factors, availability factors and economic factors.

1.6 PROJECT ORGANIZATION

This project was arranged into five chapters, chapter one as an introduction to the project. Chapter two deals with relevant literature review of the project. Chapter three deals with design procedures/circuit analysis, and component selection. Chapter four is construction, testing and enclosure, while five gives the conclusion and recommendation for upgrading the project.

CHAPTER TWO

LITERATURE REVIEW

2.0 INTRODUCTION

In this chapter, the work done by other writers that are relevant to the research work is presented, the basic theories behind the working principles of the important components are also discussed. It also highlights the limitation and lapses that had been undertaken on projects concerning electrical time table display.

2.1 HISTORICAL BACKGROUND

The dominant display technologies today are Light Emitting Diode (LEDs) and Light Crystal Display (LCDs). LEDs emerged in the early 1960s by using semiconductor light emitting theory. As an Engineer at Bell labs, Dr. Stibitz used surplus relays, tin constrip, flash light bulbs and other canonical items to construct his model "k" (for kitches table) which display the results.

Furthermore, another attempt was made (2007) titled "Design and construction of decorative lamp control system", which was successfully carried out. The project was designed in such a way that the astable multivibrator generate continuous square waveform clock pulse, by the use of 555 timers connected in the astable mode.

The clock pulses drives a decade counter which in turn switches the TRIAC Tip 41 into its conduction stage and this enable the lamps to light sequentially and later all the lamps will light. The power supply to the circuit is provided by a 12v dc regulated power circuit.

However, the design and construction of fan remote control is carried out so as to control the speed of fan using remote control without using the permanent rotary switch regulator. In this project, the astable multivibrator is used to generate the pulses which supply the decade counter with the necessary clock which subsequently count as a result switch on the transistor which allows current to flow thereby lighting the LED.

2.2 COMPONENTS REVIEW

To construct this circuit, it is necessary to briefly discuss some major components used in the construction of the project.

2.2.1 TRANSFORMER: Its function is either to step up of (mostly) step down the ac supply voltage to suit the requirement of the solid-state electronic devices and circuit fed by the dc power supply. It also provide isolation from the supply line-an important safety consideration.

See appendix g for circuit diagram.

2.2.2 RECTIFIER: It is a circuit which employs one or more diode to convert ac voltage into pulsating dc voltage.

See appendix f for circuit diagram

2.2.2.1 VOLTAGE REGULATOR: Its main function is to keep the terminal voltage of the dc supply constant even when: (i) ac input voltage to the transformer varies (deviation from 220v are common); or (ii) the load varies. Usually, zener diodes and transistors are used for voltage regulation purposes. Again, it is impossible to get 100% constant voltage but minor variation are acceptable for most of the jobs.

Strictly speaking, all that is really required for conversion from ac to dc is a transformer and a rectifier (infact even the transformer could be eliminated if no voltage transformation is required).

$$\% \text{regulation} = \frac{V_{max} - V_{min}}{V_{max}} \times 100$$

V_{max} = the maximum dc output

V_{min} = the dc minimum output voltage

See appendix h for circuit diagram

2.2.3 RESISTOR: Oppose (or restrict) the flow of electricity. According to ohm's law the voltage depend on the current and the resistance.

$$V = IR$$

$$\text{And } R = \frac{V}{I}$$

Therefore, resistance is voltage flow per unit current.

A property of a substance due to which it opposes or restricts the flow of electricity is called resistance.

See appendix a and b for circuit diagram

2.2.4 CAPACITOR: The purpose of a capacitor is to store electric charge or energy by electrostatic stress in, the dielectric. The property of a capacitor to store charge or electricity may be called its capacitance.

$$C = \frac{Q}{V}$$

Where Q = Charge

V = Voltage or potential difference

One farad is actually too large for practical purposes. Hence, much smaller units like micro farad (μf), nanofarad (nF) and micro microfarad ($\mu\mu f$) or picofarad (pF) are generally employed.

Incidentally, capacitance is that property of a capacitor which delays and change voltage across it.

See appendix i, j and k for circuit diagram

2.2.5 LED: As the name indicates is a forward bias PN-junction which emits visible light when energized. Charge carrier recombination takes place when the negative from the N side cross the junction and re-combine the holes on the p side.

See appendix i for circuit diagram

2.2.6 TRANSISTOR: Transistor is essential to apply voltage of correct polarity across the two junctions. It is worthwhile to remember that for normal operation

- (i) emitter base junction is always forward bias and
- (ii) collector base junction is always reverse bias.

This type of biasing is called FR biasing (i.e. forward reverse biasing).

See appendix a and b for circuit diagram

2.2.7 SWITCH: Electronics switch is an electrical component that can break an electrical circuit, interrupting the current or diverting it from one conductor to another. An ideal switch describes a switch that:

- Has no current limit during it ON state
- Has infinite resistance during it OFF state
- Has no voltage drop across the switch during it ON state
- Has no voltage limit during its OFF state
- Has zero rise time and fall time during states changes
- Switches without "bouncing" between ON and OFF positions.

The ideal switch is often used in circuit analysis as it greatly simplifies the system of equations to be solved, however this can lead to a less accurate solution.

See appendix i for circuit diagram

2.2.8 NE 555 TIMER: The 555 timer IC is an integrated circuit (chip) used in a variety of timer, pulse generation and oscillator applications.

See appendix n for circuit diagram

2.2.9 CD 4017BC DECADE COUNTER: In electronics, counter is a device which stores (and sometimes displays) the number of times a particular event or process has occurred. Often in relationship to a clock signal. Decade counter counts through ten states per stage. Decade counter is one that counts in decimal digits, rather than binary. A decade counter may have each digit binary encoded. Alternatively, it may have a “fully decoded” or one-hot output code in which each output goes high in turn such a circuit is control by CD4017BC.

See appendix o for circuit diagram

CHAPTER THREE

3.0 DESIGN ANALYSIS

The general mathematical and methodology used to achieve this project is described in this chapter. The mathematical parameters of this project are designed to correspond with practical design.

3.1 DESIGN OF THE POWER SUPPLY

Theoretically, the power supply consist of a step-down transformer, a bridge rectifier and a capacitor filter circuit

THE STEP DOWN TRANSFORMER

Theoretically, a step-down transformer was used for this project of 200watt rating; the essential factors of parameters are as shown below:

$$[E. m. f.]_{\text{prim}} = 220\text{VAC}$$

$$[E. m. f.]_{\text{sec}} = 15\text{VAC}$$

$$\text{Number of turn in the primary} = 500\text{T}$$

$$[\text{No. T}]_{\text{sec}} = \frac{E_s \times N_p}{E_p}$$

$$= \frac{15 \times 500}{220} = 34\text{Turns}$$

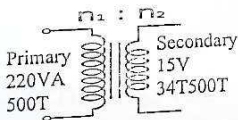

Fig. 2: Circuit diagram of a step-down transformer

The current (Amps) consumption of the primary turns of the transformer.

$$P = IV$$

$$P.F = \cos$$

$$I = P/V\cos$$

$$\text{At } P_{\max}, \cos = 1$$

$$\text{Thus; } I = P/V$$

$$I = 200/220$$

$$I = 0.9 \text{ Amps.}$$

The winding ratio of the transformer is

$$\frac{P_{\text{r turns}}}{S_{\text{c turns}}}$$

$$= 500T/34T = 14.7 \text{ ratio}$$

Then the secondary current supply of the transformer is

= winding ratio x primary current

$$\frac{I_2}{I_1} = K$$

$$I_2 = I_1 K$$

$$14.7 \times 0.9$$

$$= 13.23 \text{ Amps.}$$

3.1.1 THE RECTIFIER STAGE

The A.C Rectification stage was built with 2 diodes as full-wave center tapped rectifier as shown below:

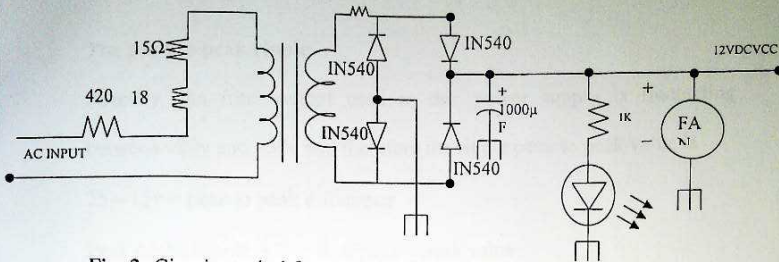

Fig. 3: Circuit symbol for power supply

Peak value of AC input at the 220V input is 339.40 peak (V_{in}) applied to the primary of the transformer, then the average output voltage from the full wave centre tapped rectifier is 15v.

3.12 THE CAPACITIVE FILTER

The capacitive filters were used as a clamp for the rectifier. They were used to suppress ripples current after rectification while not affecting the direct current as shown below:

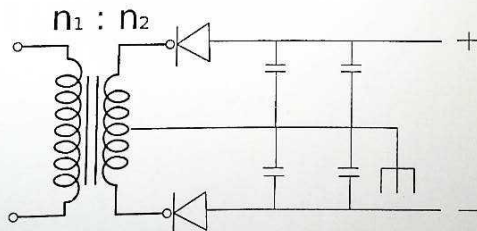

Fig. 4: capacitive filter

Important parameter of the D.C filter circuit that was considered include:

The peak to peak ripple: -

Actually, the filter output used in this power supply is fluctuating between +20v and +30v and therefore the ripple peak to peak value is

25 - 15v = peak to peak difference

Peak of the Ripple = $\frac{1}{2}$ of peak - peak value

= $\frac{1}{2}$ of 10v

= 5V_{peak value}

The Ripple R.M.S is

= 0.0707 x peak value

= 0.070 x 5v

= 3.54v

Then the ripple percent = $V_{rms} \text{ of ripple} / V_{Avr} \text{ of ripple} \times 100\%$

% = $3.5V / 15V \times 100\%$

% = 23%

3.2 DESIGN OF THE OSCILLATOR

The oscillator was built using the world most populous I.C (NE555) with its pin out configurations shown below:

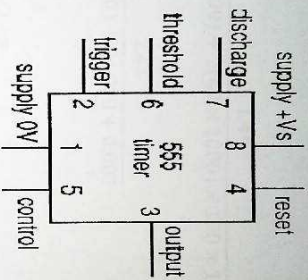

Fig. 5

The circuit diagram of the oscillator is show below.

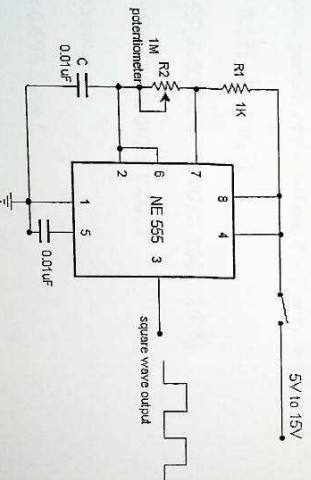

Fig. 6

In the circuit above, R_1 , R_2 and d.c. determine the frequency of the oscillator.

The frequency of the oscillator can be determined with:

$$\begin{aligned}
 F &= 1/T = \frac{1.44}{R_A + 2R_B} \times C \\
 &= \frac{1.44}{(220,000) + 2(47 \times 1000) \times 100 \times 10^{-6}} \\
 &= \frac{1.44}{(220,000) + 94,000 + 0.001} \\
 &= 1.44/31.4 \\
 &= 0.046 \text{ or } 4.6\text{Hz}
 \end{aligned}$$

The total periods of oscillation, T is $T = t_H + t_L$

$$\begin{aligned}
 t_H &= 0.695 (R_A + R_B) C \\
 &= 0.695(220,000 + 47000) \times 100 \times 10^{-6} \\
 &= 0.695 \times (267,000) \times 0.0001 \\
 &= 18.556\text{ms} \\
 t_L &= 0.695 R_B \times C \\
 &= 0.695 \times 47,000 \times 100 \times 10^{-6} \\
 &= 0.695 \times 47,000 \times 0.001 \\
 &= 3.26\text{ms}
 \end{aligned}$$

$$T = T_H + T_L$$

$$T = (18.5565 + 3.26)m_s$$

$$T = 21m_s$$

$$F = 1/T = 1/21.8m_s = 0.045 \text{ or } 4.5Hz$$

The duty cycle (Dc) is the ratio of time when the output is low t_L to the total period.

$$\begin{aligned} D_c = t_L &= \frac{R_B}{R_A + 2R_B} \\ &= \frac{47000}{(220,000) + 2 \times 47,000} \\ &= \frac{47000}{(220,000) + 94,000} \\ &= \frac{47000}{220,000 + 94,000} \\ &= \frac{47000}{314000} \\ &= 0.15\% \end{aligned}$$

3.3 THE FREQUENCY DIVIDERS

The frequency dividers were built using CD4017 as shown below:

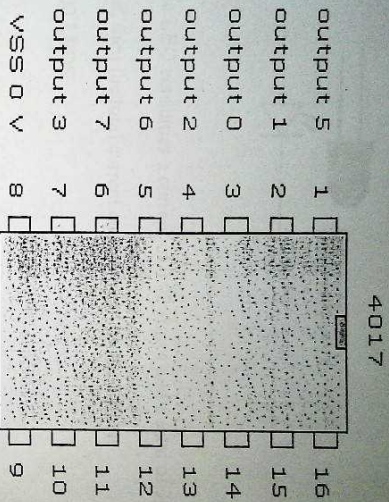

Fig. 7

The CD4017 was used as a Johnson counter. Its counting steps can be determined as:

$$\frac{= \text{Freq. in}}{\text{no. of output used}}$$

In this project, if the frequency is roughly 4Hz then, the output frequency would be

3.4 THE DESIGN OF THE LED

The symbols and physical appearance of an LED is shown below:

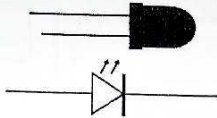

Fig. 8

If a single LED consumes a current of 0.02 Amps and a total of 300 LED

were used, then the total current consumption by the LED is

$$0.03 \times 300 \text{ LEDS}$$

$$= 9 \text{ Amps}$$

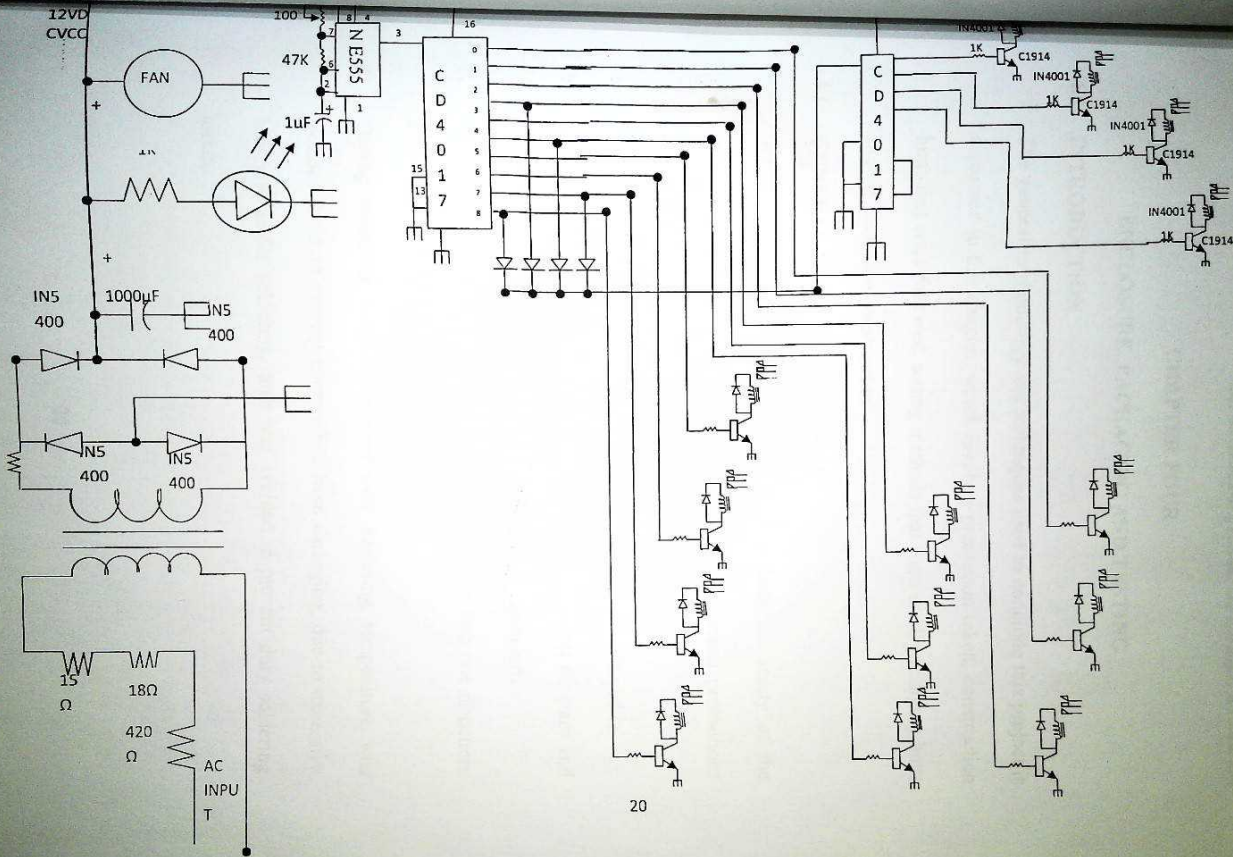

CHAPTER FOUR

ENCLOSURE, PACKAGING AND TESTING

4.0 INTRODUCTION

The general methodology and techniques used to conclude this project is discussed in this chapter, which involves precaution taken, construction hints that were followed, testing methods that were used, packaging hints and the enclosure construction.

4.1 GENERAL PRECAUTION TAKEN

Safety is everything in any technical design both the safety of the personnel and the devices were considered. Some general precautions taken include the following:

- a. Ensuring that all electrical regulations and IEE rules were adhered to.
- b. Before the practical construction was executed the circuit diagram and design were first analyzed to ensure that they are free from errors.
- c. During construction layout, all I.C were mounted to face one direction, not staggered to ensure easy trouble shooting.
- d. During soldering construction time over soldering temperature was avoided so as to prevent components from damaging, due to excessive heat also under soldering, time was avoided to prevent duty soldering joints.

- c. After the construction was completed the circuit board was washed with Ethanol so as to dissolve conductive mineral contaminations and to remove tiny lead particles that could cause short circuit.
- f. IC base devices were used except for power ICs so as to make I.C substitution convenience during any damage or design error.

4.2 TESTING AND TESTING METHODS

There were three testing methods that were employed. They are prototype testing, qualification testing and production testing.

Prototype Testing

The prototype testing may still be referred to as the bread boarding. Before the permanent construction was done, the prototype testing using breadboard was done to thoroughly prove that the circuit design will meet the specifications, also to reveal any inadequacies in either performance or parameter.

As a result of prototype testing, two errors were revealed i.e. design error, part error and they were fixed.

Qualification Testing

Qualification testing was carried out to ensure that the constructed project fulfils the technical requirements such as operational requirements, voltage requirements, frequency requirements etc.

Production Testing

The production testing is simply the construction testing. The construction testing was used to verify the conformity of the finished construction.

4.3 CONSTRUCTION HINTS AND PACKAGING

In general, the front panel of the enclosure were used for indicators, metres etc. as well as controls and frequently used connector.

It is a common practice to put seldom, used adjustments and connectors that don't require frequent access on the rear or back panel of the enclosure. Along with A.c wires, fuses etc. the most important thing that was remembered during layout and packaging is the need for good accessibility to circuit without great pain. This means neat cabling of wiring so that circuit boards can be raised without unsoldering and could be tested while operating.

4.4 GENERAL CAUSES OF FAILURE AND PRECAUTIONS

The failure of a component in an equipment may lead to the failure of that equipment. The general cause of failure and their remedies includes:

- a. **The Effect of Temperature:** According to Arrhenius law, it states that failure rate of a component approximately doubles with every 10^0 rise in temperature for a fixed voltage. Therefore, the effect of temperature can

be reduced through the use of heat sinks, cooling fans and enclosure perforation for cross ventilation.

- b. **The Effect of Humidity:** Under this condition, a thin form of water known as water vapor can be formed on a component and the surface of the printed circuit board can become consequently ionized and form an undesirable conducting path. The only remedy for this problem is that the enclosure material must not support the absorbent of water.

- c. **The Effect of Mechanical Vibrations and Shocks**

Since all equipments are subjected to mechanical vibrations and shocks which may weaken equipment support, loosen wires, bend some components with long leads. The effect of mechanical vibration and shocks can be resolved by using anti-vibration mountings, shake-proof washers, locking nuts and by encapsulating sensitive components.

4.5 ENCLOSURE

The dimensions of the enclosure used in this project is 34×19 inches.

The various photo views of the enclosure is also shown below:

Design and construction of electronic line table display with output voice

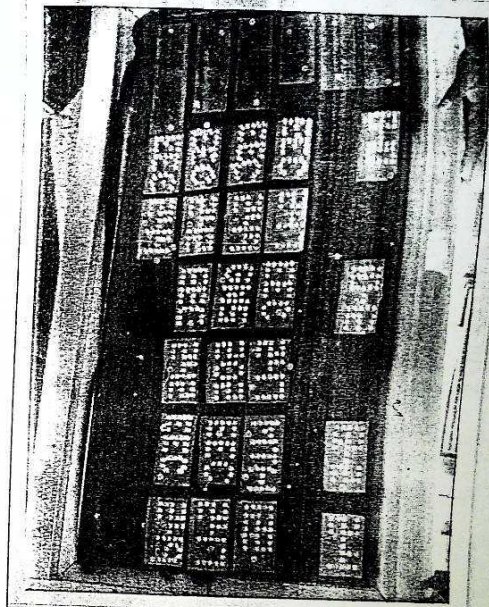

19 inches

34 inches

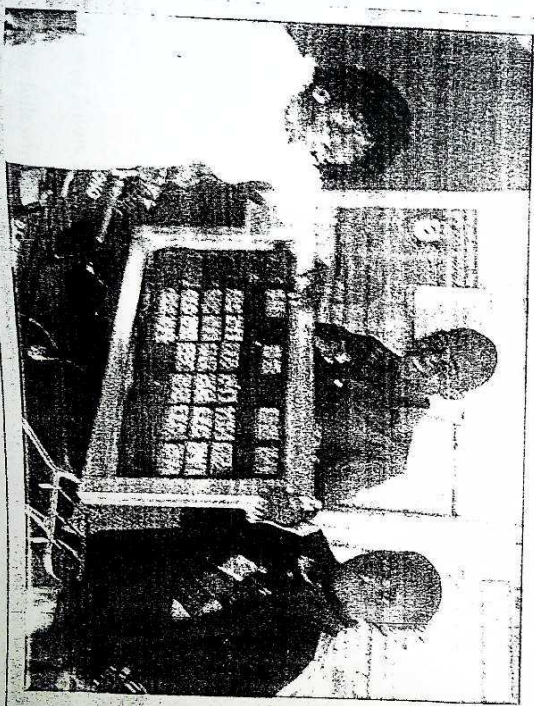

CHAPTER FIVE

5.0 CONCLUSION AND RECOMMENDATION

5.1 CONCLUSION

In conclusion, the electronic time table display with an output voltage was designed and constructed in such a way that the LEDs were arranged to display the time table and the alarm to draw attention of both the students and staff that its time to change period.

The design basically utilized diode/rectifiers, resistors, capacitors, transformers, switch, NE 555 timer, transistor, CD4017 decade counter, regulator and the LEDs.

After the construction of the project, the enclosure was made with the exact measurement and after the packaging, we tested it and it was tested okay.

5.2 RECOMMENDATION

It is recommended that the circuit can be modified into another form of design and used in different area of application e.g. an audible alarm can be connected instead of light emitting diode (LED) to give different alarm sound or alternatively can be used in telecommunication system.

However, 12v battery that will serve as a standby can be included, in case of power failure and the circuit can be designed using microcontroller and also the following are recommended: -

- Student should be provided with current journals, manuals and text book which will increase the understanding and challenge in design and construction.
- Government should make electronics components available for students who wish to work for electronics projects.
- Seminar and symposium workshop should be encouraged in the department to enlighten students in the department about design and construction.
- Government and financial institution should be looking into the students project with the view of improving them for the benefit of the society.

REFERENCES

- B.L. Theraja (1999): A textbook of Electrical Technology volume 1.
- D.C. Green: (1981): Electronics IV fourth edition, Longman group Ltd London.
- Weller .F. (1978); Handbook of Electrical system design; (third edition) Reston Publishing Company Inc. Reston Virginia, USA.
- R. Maddock and MD. M. Calcartt: A course for Engineers

APPENDIX A LIST FIGURE



a. Fixed Resistor



b. Variable Resistor



c. Diode



d. Zener Diode

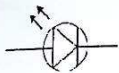

e. LED

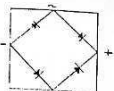

f. Full wave rectifier



g. Transformer



h. Regulator

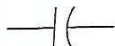

i. Fixed polarized capacitor

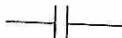

j. Fixed capacitor

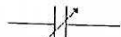

k. Variable capacitor

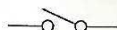

l. Switch

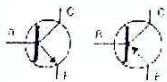

NPN

PNP

m. NPN and PNP Transistors

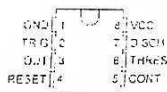

n. NE 555 Timer

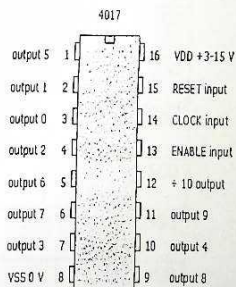

o. CD4017Bc

BILL OF QUANTITY

S/N	ITEM	QTY	UNIT PRICE (₦)	TOTAL PRICE (₦)
1.	Transformer	4	410	1640
2.	Rectifier	2	45	90
3.	DC filter	4	115	460
4.	Vero board	20	100	2000
5.	Leads	2 rolls	1000	2000
6.	AC cord	2	75	150
7.	Jumper wires			1200
8.	LEDs	1200	10	12000
9.	Soldering iron	2	60	120
10.	Bread board	1	600	600
11.	IC sockets	10	30	300
12.	Razor blades	10	10	100
13.	NE555 Timer	6	100	600
14.	CD4017 (Decade counter)	13	120	1560
15.	Transistors	20	45	900
16.	Relays			400
17.	Super glue	8	50	400
18.	Capacitors	4	25	100
19.	Resistor s			300

Design and construction of electronic time table display with output voice

20.	Choke Resistors			
21.	Battery	2		460
22.	Digital multimeter		100	200
23.	Spray paint	1	500	500
24.	Enclosure	1	650	650
25.	Miscellaneous			8500
26.	Screw driver			6500
27.	Consultionary services			200
28.				1500
		Total		₦43,430